

**5** OUTBOARD  
YEARS  
warranty

FOR LEISURE USE ONLY  
Selva 50 terms and conditions  
see your Dealer for more  
information



**SELVA**<sup>TM</sup>



Tender Line

Cruiser Tender  
Line

Plein Air  
Line

# INFLATABLE BOATS WITH OUTBOARD MOTOR



**f** Selva Marine

**Tender Line**

Selva Marine engines come with a five-year limited warranty. Certain conditions and exclusions apply including professional and commercial use.

**5** OUTBOARD  
**YEARS**  
warranty

FOR LEISURE USE ONLY  
Subject to terms and conditions  
in your Dealer for more  
information



Inflatable boats in a ready packaged formula with **Selva Marine** outboard motors come in 7 ranges with 8 different construction types: to be chosen among the normal rolling-up version; the folding model with wooden floor; the 'V'-shape inflatable keel model; or the fibreglass hull, (single or double moulded), or even with foldable hull. There are even the single or double lighter-weight aluminium hull models. All ideal for use as tenders, with lengths from two to four metres.

**Tender Line**

RANGE **DA**  
MODEL **T 340**



Model	Max length (cm)	Max beam (cm)	Dry weight (kg)	People carrying capacity
T 340 DA	340	154	67	4+1*

RANGE **A**  
MODEL **T 340 - T 310**

**Tender Line**



Model	Max length (cm)	Max beam (cm)	Dry weight (kg)	People carrying capacity
T 340 A	340	154	54	4+1*
T 310 A	307	159	47	4+1*

1\* = N°1 child

**Tender Line**

RANGE **FV**  
MODEL **T 310**



*Model T 310 FV*

Model	Max length (cm)	Max beam (cm)	Dry weight (kg)	People carrying capacity
T 310 FV	310	150	55	4

RANGE **DV**

MODEL **T 400 - T 350 - T 310 - T 280**

**Tender Line**



Model/T 310 DV

Model	Max length (cm)	Max beam (cm)	Dry weight (kg)	People carrying capacity
T 400 DV	395	180	106	6
T 350 DV	348	176	73	4
T 310 DV	308	154	58,4	4
T 280 DV	282	172	58	4



Model T 255 V

Model	Max length (cm)	Max beam (cm)	Dry weight (kg)	People carrying capacity
T 355 V	354	171	55,9	4
T 325 V	323	152	51,2	3+1*
T 285 V	285	154	45,7t	3
T 255 V	253	155,5	43,23	3

1\* = N°1 child

RANGE **V**  
MODEL **T 255**

**Tender Line**



*Model T 225 V*

Model	Max length (cm)	Max beam (cm)	Dry weight (kg)	People carrying capacity
T 225 V	224	152,5	34,9	3



**Tender Line**

RANGE **VIB**  
MODEL **T 380 - T 350**



Model **T 350 VIB**

Model	Max length (cm)	Max beam (cm)	Dry weight (kg)	People carrying capacity
T 380 VIB	376	170	47,56	5+1*
T 350 VIB	349	170	41,95	5

1\* = N°1 child

# RANGE VIB

MODEL T 320 - T 270 - T230

**Tender Line**

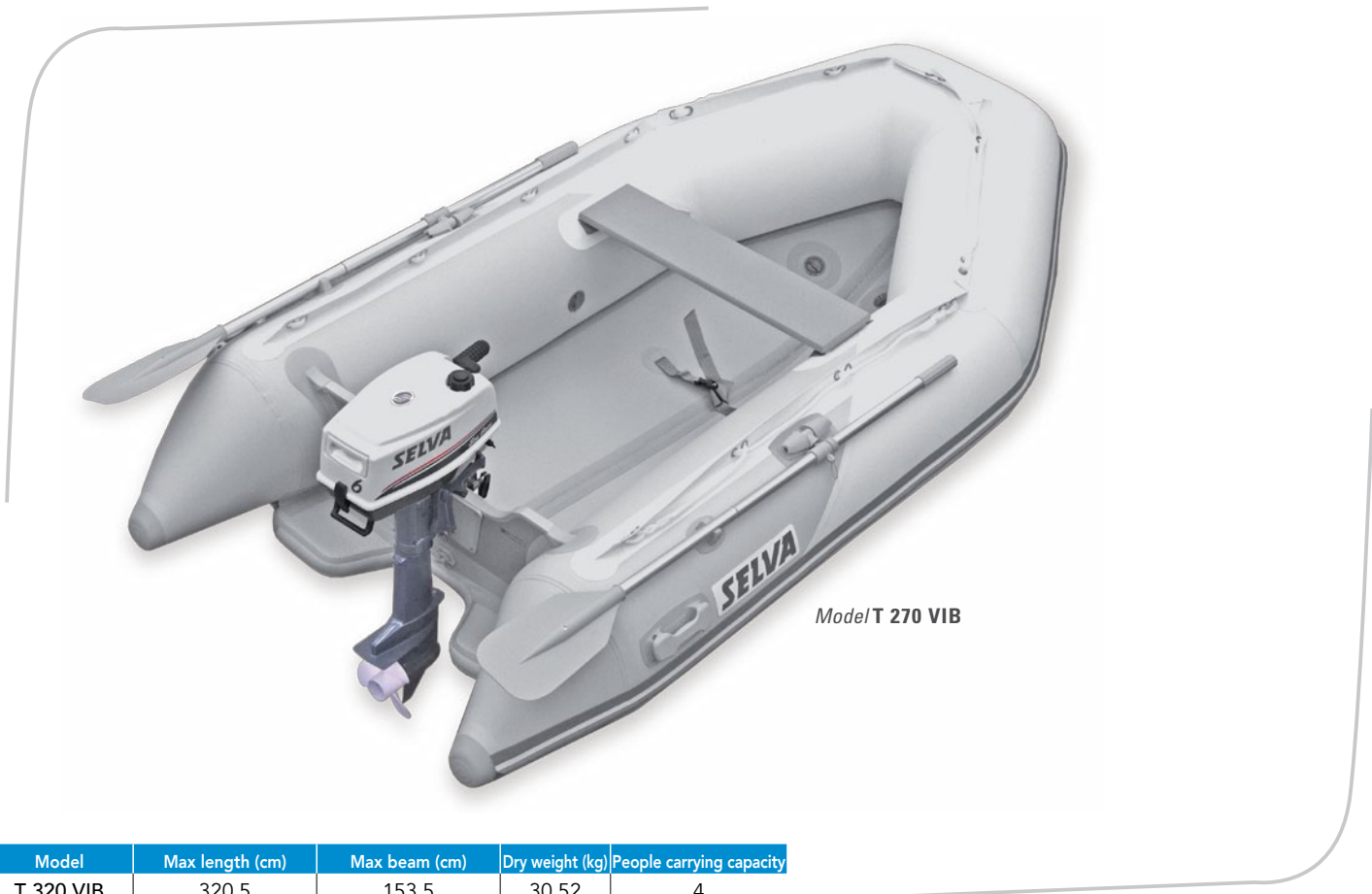

Model	Max length (cm)	Max beam (cm)	Dry weight (kg)	People carrying capacity
T 320 VIB	320,5	153,5	30,52	4
T 270 VIB	267	153	26,76	3+1*
T 230 VIB	232	135	18,37	2+1*

1\* = N°1 child

## Tender Line

RANGE **RL**

MODEL T 260 - T 230 - T 200

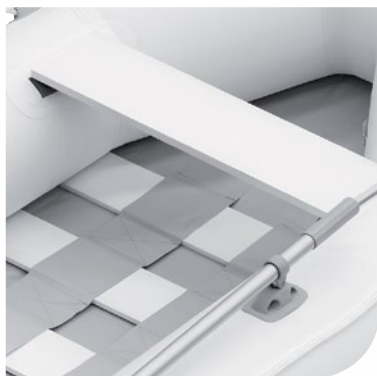

Model T 230 RL

Model	Max length (cm)	Max beam (cm)	Dry weight (kg)	People carrying capacity
T 260 RL	253	148,5	24	3
T 230 RL	225	131	21,1	2+1*
T 200 RL	197	131	16,6	1+1*

1\* = N°1 child

Model	T 340 DA	T 340 A	T 310 A	T 310 FV	T 400 DV	T 350 DV	T 310 DV	T 280 DV
Max length (cm)	340	340	307	310	395	348	308	282
Max width (cm)	154	154	159	150	180	176	154	172
Tube diameter (cm)	41	41	42	40	47	47,5	41,5	44,5
Floor area (m2)	1,41	1,41	1,21	1,32	2,1	1,59	1,35	1,36
Number of compartments	3	3	3	2	3	3	3	3
Pressure (bar)	0,25	0,25	0,25	0,25	0,25	0,25	0,25	0,25
Weight (kg)	67	54	47	55	106	73	58,4	58
Max power applicable kW/hp	14,7 ( 20 )	14,7 ( 20 )	14,7 ( 20 )	7,4 ( 10 )	22,1 ( 30 )	11 ( 15 )	11 ( 15 )	11 ( 15 )
Max engine weight applicable (kg)	60	60	60	55	90	60	60	55
People carrying capacity	4 + 1*	4 + 1*	4 + 1*	4	6	4	4	4
Max carrying load (kg) - people, standard equipment, engine	550	550	495	400	850	600	500	600
Type	Rigid hull in ALUMINIUM Double moulded	Rigid hull in ALUMINIUM		GRP foldable rigid hull, with reclining transom	Rigid GRP Double moulded hull			
Hull outer/inner colour	White							
Tube colour	White							
Fabric	PVC 1.100 g/m <sup>2</sup>							
Type of motor shaft	Short							
Design category	C	C	C	C	C	C	C	C

Model	T 355 V	T 325 V	T 285 V	T 255 V	T 225 V	T 380 VIB	T 350 VIB	T 320 VIB	T 270 VIB	T 230 VIB	T 260 RL	T 230 RL	T 200 RL	
Max length (cm)	354	323	285	253	224	376	349	320,5	267	232	253	225	197	
Max width (cm)	171	152	154	155,5	152,5	170	170	153,5	153	135	148,5	131	131	
Tube diameter (cm)	41	42	41,5	41	39	44	44,5	42,5	42,5	35	38,5	35	35	
Floor area (m2)	1,71	1,53	1,15	0,97	0,79	1,91	1,63	1,41	1,07	0,88	0,883	0,854	0,677	
Number of compartments	3	3	3	3	3	5	5	5	5	4	3	3	2	
Pressure (bar)	0,25	0,25	0,25	0,25	0,25	Tubular 0.25 - Hull 0.8					0,25	0,25	0,25	
Weight (kg)	55,9	51,2	45,7	43,23	34,9	47,56	41,95	30,52	26,76	18,37	24	21,1	16,6	
Max power applicable kW/hp	11 ( 15 )	11 ( 15 )	7,4 ( 10 )	4,78 ( 6,5 )	3,67 ( 5 )	14,7 (20)	11 (15)	11 (15)	6 (8)	3,67 ( 5 )	3,7 (5)	2,4 (3,3)	1,8 (2,5)	
Max engine weight applicable (kg)	50	60	55	40	40	83	60	60	55	40	40	24	24	
People carrying capacity	4	3 + 1*	3	3	3	5 + 1*	5	4	3 + 1*	2 + 1*	3	2 + 1*	1 + 1*	
Max carrying load (kg) - people, standard equipment, engine	640	600	510	460	350	950	900	735	664	380	400	270	250	
Type	Rigid GRP hull					V inflatable keel					Slatted floor			
Hull outer/inner colour	White													
Tube colour	White													
Fabric	PVC 1.100 g/m <sup>2</sup>										PVC 550 g/m <sup>2</sup>			
Type of motor shaft	Short													
Design category	C	C	C	C	-	C	C	C	C	-	C	-	-	

Model	T 340 DA	T 340 A	T 310 A	T 310 FV	T 400 DV	T 350 DV	T 310 DV	T 280 DV
Oars in fixed rowlocks	S	S	S	S	S	S	S	S
Inflating pump	S	S	S	S	S	S	S	S
Carrying bag	N	N	N	S	N	N	N	N
Carrying backpack	N	N	N	N	N	N	N	N
Lifelines	S	S	S	S	S	S	S	S
Fender profile	S	S	S	S	S	S	S	S
Towing ring	N	N	N	S	S	S	S	S
Handles	S	S	S	S	S	S	S	S
Motor support plates	S	S	S	S	S	S	S	S
Removable motor support	N	N	N	N	N	N	N	N
Bow locker with closure	S	N	N	N	S	S	S	S
Folding GRP hull	N	N	N	S	N	N	N	N
Folding transom	N	N	N	S	N	N	N	N
UV protection cover	O	O	O	O	O	O	O	O
Repair kit	S	S	S	S	S	S	S	S

Model	T 355 V	T 325 V	T 285 V	T 255 V	T 225 V	T 380 VIBT	T 350 VIBT	T 320 VIBT	T 270 VIBT	T 230 VIBT	T 260 RL	T 230 RL	T 200 RL
Oars in fixed rowlocks	S	S	S	S	S	S	S	S	S	S	S	S	S
Inflating pump	S	S	S	S	S	S	S	S	S	S	S	S	S
Carrying bag	N	N	N	N	N	S	S	S	S	S	S	S	S
Carrying backpack	N	N	N	N	N	N	N	N	N	N	N	N	N
Lifelines	S	S	S	S	S	S	S	S	S	S	S	S	S
Fender profile	S	S	S	S	S	S	S	S	S	S	S	S	S
Towing ring	S	S	S	S	S	S	S	S	S	S	S	S	S
Handles	S	S	S	S	S	N	N	N	N	N	N	N	N
Motor support plates	S	S	S	S	S	S	S	S	S	S	S	S	S
Removable motor support	N	N	N	N	N	N	N	N	N	N	N	N	N
Bow locker with closure	N	N	N	N	N	N	N	N	N	N	N	N	N
Folding GRP hull	N	N	N	N	N	N	N	N	N	N	N	N	N
Folding transom	N	N	N	N	N	N	N	N	N	N	N	N	N
UV protection cover	O	O	O	O	O	O	O	O	O	O	O	O	O
Repair kit	S	S	S	S	S	S	S	S	S	S	S	S	S

S = Standard  
O = Optional  
N = Not available

\* = N° 1 child

For information on engines in packages with **TENDER LINE** boats, see outboard engine catalogue. The data contained in these tables are to be considered as approximate and **Selva S.p.A.** reserves the right to modify the technical characteristics, materials, construction, weights, colours, graphics, etc., without any forewarning or obligations. The specifications in this table are determined in accordance with the regulations in force at the time of preparation of the catalogue and may be modified. Please request confirmation of the data at time of purchase.

# RANGE CRT

MODEL 325 - 345 - 365

Cruiser Tender  
Line



Model CRT 365 P

Model	Max length (cm)	Max beam (cm)	Dry weight (kg)	People carrying capacity
CRT 365	365	183	145	6
CRT 345	345	179	140	5+1*
CRT 325	324	171	135	5

1\* = N°1 child

Model	CRT 365	CRT 345	CRT 325
Max length (cm)	365	345	324
Internal length (cm)	268	252	237
Max width (cm)	183	179	171
Internal width (cm)	86	83	81
Tubes diameter cm	45	45	42
Inflation pressure (atm)	0,2	0,2	0,2
Number of compartments	3	3	3
Motor shaft version	Lungo	Lungo	Lungo
Dry weight ex motor, fittings, liquids (kg)	145	140	135
People carrying capacity	6	5+1*	5
Max carrying load (kg)(people, standard equipment, engine)	800	750	550
Max applicable power (kW/hp)	29,8 (40)	22,1 (30)	18,4 (25)
Recommended power (min/max hp)	20 / 25	20 / 25	20 / 25
Hull type	DEEP V WITH SUPPORT SKIDS		
Hull material	GRP DOUBLE MOULDED		
Internal hull colour	WHITE		
External hull colour	WHITE		
Fabric	PVC 1.100 g/m <sup>2</sup> (P Version) or Ypalon 1.100 g/m <sup>2</sup> (H Version)		
Design category	C		

Model	CRT 365	CRT 345	CRT 325
Pair of paddles	S	S	S
Inflating pump	S	S	S
Motor installation	S	S	S
Complete electrical system	S	S	S
Complete driving console <sup>(1)</sup>	S	S	S
Driving seat with cushion and backrest and access to the locker underneath	S	S	S
Central console side seat with cushion	S	S	S
Bow seat with cushion and access to the locker underneath	S	S	S
Rev counter	S/O	S/O	S/O
Mooring cover	O	O	O
Repair kit	S	S	S

S = Standard  
O = Optional

S/O = Standard / Optional depending on ordered boat type

\* = N° 1 child

For information on engines in packages with **CRUISER TENDER LINE** boats, see outboard engine catalogue.

The data contained in these tables are to be considered as approximate and **Selva S.p.A.** reserves the right to modify the technical characteristics, materials, construction, weights, etc. without any forewarning or obligations.

The specifications in this table are determined in accordance with the regulations in force at the time of preparation of the catalogue and may be modified.

Please request confirmation of the data at time of purchase.

<sup>(1)</sup> Console complete with stainless steel grab-rail, single-lever remote-control box, ergonomic steering wheel, single-cable steering gear, hatch with access to locker below.

**Plein Air  
Line**

Selva Marine engines come with a five-year limited warranty. Certain conditions and exclusions apply including professional and commercial use.

**5** OUTBOARD  
YEARS  
warranty

FOR LEISURE USE ONLY  
Subject to terms and conditions  
in your Dealer for more  
information



Inflatable boats in package formula with **Selva Marine** outboard motors.

Folding range with aluminium floor, with length from 3,2 to 4,6 metres.

All the boats are equipped with a double transport bag for the inflatable and for the aluminium floor.





Model PA 460 ALU

Model	Max length (cm)	Max beam (cm)	Dry weight (kg)	People carrying capacity
PA 460 ALU	456.5	200	93,27	8
PA 430 ALU	429	202	92,4	8

# RANGE ALU

MODEL PA 390 - PA 360 - PA 320

Plein Air  
Line



Model PA 320 ALU

Model	Max length (cm)	Max beam (cm)	Dry weight (kg)	People carrying capacity
PA 390 ALU	383	169	70,3	6
PA 360 ALU	355	171	66,25	5
PA 320 ALU	315	152	51	4

Model	PA 460 ALU	PA 430 ALU	PA 390 ALU	PA 360 ALU	PA 320 ALU
Max length (cm)	456.5	429	383	355	315
Max width (cm)	200	202	169	171	152
Tube diameter (cm)	52,5	52	43,5	45,5	42
Floor area (m <sup>2</sup> )	2,69	2,59	1,95	1,68	1,25
Number of compartments	5+1	5+1	3+1	3+1	3+1
Pressure (bar)	Tube 0.25 Hull 0.35				
Weight (kg)	93,27	92,4	70,3	66,25	51
Max power applicable kW/hp	29,4 (40)	22,5 (30)	18,4 (25)	14,7 (20)	11 (15)
Max engine weight appli- cable (kg)	108	90	83	60	60
People carrying capacity	8	8	6	5	4
Max carrying load (kg) - people, standard equip- ment, engine	1400	1250	750	700	620
Type of floor	Detachable with aluminium floor and inflatable keel				
Hull outer/inner colour	White				
Tube colour	White/Grey				
Fabric	PVC 1.100 g/m <sup>2</sup>				
Type of motor shaft	Long		Short		
Design category	C	C	C	C	C

Model	PA 460 ALU	PA 430 ALU	PA 390 ALU	PA 360 ALU	PA 320 ALU
Pair of oars in fixed rowlocks	S	S	S	S	S
Inflating pump	S	S	S	S	S
Carrying bag	S	S	S	S	S
Lifeline	S	S	S	S	S
Fender profile	S	S	S	S	S
Towing ring	S	S	S	S	S
Motor support plates	S	S	S	S	S
UV protection mooring cover	O	O	O	O	O
Repair kit	S	S	S	S	S
Complete stainless steel steering	O	O	N	N	N

S = Standard  
O = Optional  
N = Not available

\* = N° 1 child

For information on engines in packages with **PLEIN AIR LINE** boats, see outboard engine catalogue.

The data contained in these tables are to be considered as approximate and **Selva S.p.A.** reserves the right to modify the technical characteristics, materials, construction, weights, etc. without any forewarning or obligations.

Brochure photography was undertaken under controlled conditions. Always wear your kill-cord, follow local safety rules and regulations and use appropriate clothing, lifejackets or PFDs according to possible sea and weather conditions.

Training will add to your safety and skills for you to really enjoy any boating activity. Your local dealer will be pleased to advise.



**SELVA S.p.A.**

Head office and main factory:

Viale dell'Industria, 13

23037 Tirano (SO) - Italia

Tel. 0342 702451 - Fax 0342 70536

VAT Number IT 00050830140

Company Registration SO n. 00050830140 - REA n. 18382

[www.selvamarine.com](http://www.selvamarine.com)



**Q8 Oils**